



HITACHI

ZX690LC-6 | ZX890LC-6 | ZAXIS-6 series

Reliable solutions



ZX890LC-6

SPEC SUMMARY

	ZX690LC-6	ZX890LC-6
Operating Weight	151,237 lb. (68,600 kg)	186,511 lb. (84,600 kg)
Net Power (ISO 9249)	462.7 hp (345 kW) @ 1,800 rpm	512 hp (382 kW) @ 1,800 rpm

ZAXIS 690 ZAXIS 890

Hydraulic Excavator



ENGINEERED FOR ULTIMATE CONTROL

Whether you look at performance, efficiency, or cab comfort, Hitachi's latest range of excavators was designed around enhancing the operator experience and maximizing the fleet owner's bottom line.

We've looked closely at the day-to-day challenges you face as the owner of a successful business and have improved upon the comfort, efficiency and support we offer you over the life of your excavator.

By building the ZAXIS-6 series excavators around your needs, we have given you more control than ever of your fleet on whatever job site you are on.



ZX890LC-6

CONTENTS



6. Safely under control



8. Boost your uptime



10. Performance and fine control



13. More comfort features



14. Durability comes standard



16. Reliability is the backbone of your business



18. Get more from your excavator

CONTROL YOU CAN COUNT ON

The new ZAXIS-6 large-sized excavators with three working modes (ECO, Power, and High Power) puts you firmly in control, to have your machine perform how you need it to, when you need it to. Our excavators are backed by Hitachi technological expertise and our current 4-year, 4,000-hour STD warranty. We've got this, and you're in control.



Machine representative of global product.
Options may not be available in all markets.



A large cab provides a more comfortable working environment.



The Aerial Angle® camera system and 7" LCD monitor takes visibility to a new level.



ConSite OIL sensors monitor oil quality proactively, easing your mind so that you can focus on the work that needs to be done.



The ConSite suite of apps track real-time performance metrics, making it easy for you to manage your machines' performance and productivity.



Improved access to components makes maintenance quick and easy.



The improved HIOS IIIB hydraulic system increases hydraulic efficiency while reducing fuel consumption at the same time.



The new powerful HP mode improves productivity and reduces cycle time.

SAFELY UNDER CONTROL



Safety is vital to everyone on the job site and for the successful completion of any project. The Hitachi ZAXIS-6 excavators give you a superior view of your surroundings.

The Aerial Angle® camera system allows an exceptional 270-degree bird's-eye view of the surroundings. Three views of the machine's immediate environment can be selected, allowing the operator to choose the view that best suits the situation.

ZAXIS-6 excavators come standard with an impressive array of LED work lights, lighting up your job site at night like never before.



LED working lights improve visibility in challenging conditions.

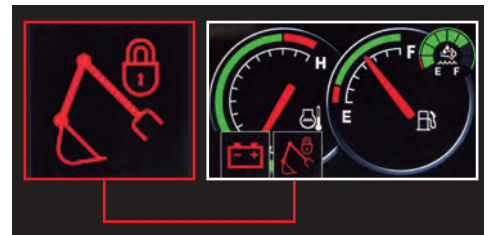

Secure operation

Control-lever auto-lock helps prevent unintentional movement of the front, swing, travel, and attachment control functions. When the control-lever auto-lock is engaged, the icon will be illustrated on the monitor and an alarm will sound.

The ZX490LC-6 ROPS cab is pressurized to help protect operators from dust and debris.



ZX890LC-6



Choose among different views to suit your jobsite and situation.

Aerial Angle® Camera comes standard

The Aerial Angle® camera system offers exceptional visibility of the job site. With a push of the screen changeover button, an operator can choose to view a combination of all three cameras, providing a 270-degree view of the excavator; right and rearview camera view; or left, right, and rearview cameras separately depending on what view best fits the work environment and situation.

The excavator surrounding camera view is a composite of the images from the right, left, and rearview cameras, offering a 270-degree birds-eye view of the excavator's immediate environment.



BOOST YOUR UPTIME

Ease of maintenance

The engine cover opens wide to reveal improved access to the engine compartment and components, making maintenance easier.

Conveniently located filters make daily inspections and maintenance easier.

Auto-Idle

Auto-Idle reduces engine speed when the machine is not working for 4 seconds.

Auto-shutdown

Shuts down your excavator if left running between 1 to 30 minutes depending on the setting set within the cab monitor.

Grouped maintenance points with easy access.



Machine representative of global product.
Options may not be available in all markets.





HITACHI

Designed for durability and easy maintenance, ZAXIS-6 excavators increase uptime and reduce the total cost of ownership.

ZX890LC-6

PERFORMANCE AND FINE CONTROL



Machine representative of global product.
Options may not be available in all markets.

HIOS IIIIB: Employs a two pump system to enhance controllability and productivity

The boom and arm are more responsive due to direct oil flow to each actuator

The pumps are controlled electronically for improved efficiency and lower fuel consumption

The SCR system injects urea into exhaust gas (red) to reduce NOx from emissions



ZX890LC-6

HIOS III B

The HIOS III B hydraulic system consists of two pumps and two control valves to reduce fuel consumption while enhancing controllability, productivity, and efficiency. (HIOS – Human & Intelligent Operation System)

The HIOS III B system increases the operational speed of the four following excavator operations:

1. Bucket Roll-out
2. Arm Roll-out
3. Boom Lowering
4. House Swing

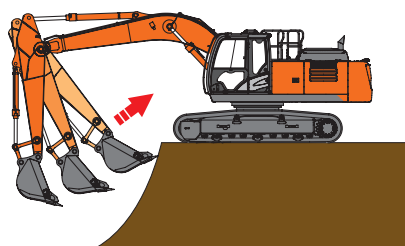

The operational speed is increased by increasing the pump flow as well as reducing pressure loss of the hydraulic circuit.

Boost Efficiency

Shortened time to complete the swing plus boom raise operation by increased pump flow and improved swing torque.

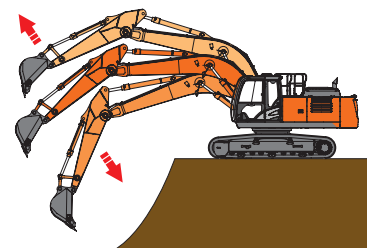

H/P (High Power) mode

H/P mode increases engine speed and pump output torque when additional speed and power are needed during operation.

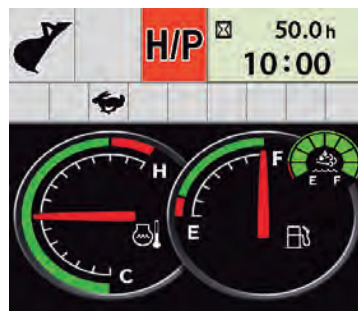

Power boost

Power boost enhances digging force up to 10%, improving excavating and lifting performance.



1

2

4

11

5

6

7

3

8

9

10

MORE COMFORT FEATURES

Enhanced comfort controls are at your fingertips in the refined cab of ZAXIS-6 excavators, giving you the power to perform with ease.

User-friendly monitor

A large 7-inch LCD monitor allows the operator to check machine status at a glance in up to 32 languages.

Improved visibility

The optional front guard has been redesigned and improved, providing the operator with an even better view of the job site.

A comfortable seat

A fully adjustable seat, spacious cab, ergonomic controls, and advanced music system all contribute to the ultimate working environment. The addition of an adjustable sun visor reduces glare on those days when the sun is low in the sky.

Advanced audio system

The AM/FM radio is readily accessible from the monitor, and an auxiliary socket for devices such as MP3 players is linked to the sound system. This choice of entertainment helps to provide an enjoyable and productive working environment.

Ease of use

A USB port in the cab enables operators to charge smartphones and tablets while they work for added convenience.

Cool, quiet cab

Features have been added to the cab to make it quieter and to reduce dust ingress.

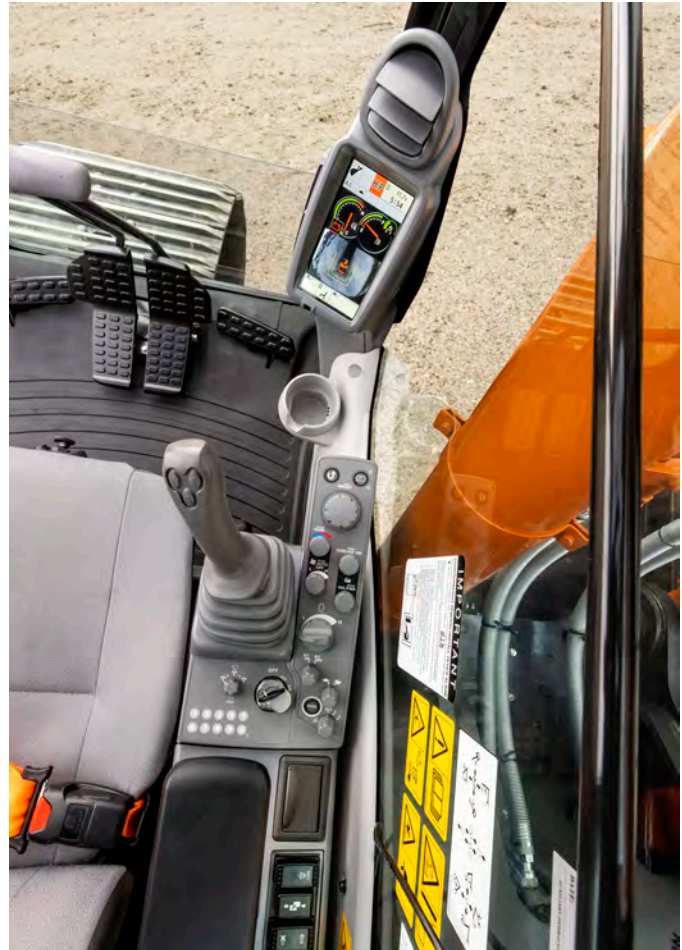

Comfortable cab space. ROPS certified CRESV cab.

- 1 Air conditioning and audio** are easily controlled via the monitor.
- 2 Low-reflective color 7" LCD monitor** is easy to view and navigate.
- 3 USB power supply and smartphone holder** helps you stay connected.
- 4 Drink holder** is easy to detach for cleaning.
- 5 Additional joystick controls** for effortless operation.
- 6 Ergonomic design** gives you convenient access to controls.
- 7 Multifunctional control panel** makes operation easier.
- 8 Improved sound isolation** makes this one of the quietest cabs on the market.
- 9 User-friendly storage space** keeps your workspace tidy and clutter-free.
- 10 Coat hooks** take care of your personal belongings.
- 11 Optimal pedal layout** helps to reduce fatigue.

DURABILITY COMES STANDARD



Enhanced fuel circuit

A high-performance water separator and cold fuel resistance valve are integrated into the pre-filter for added protection against moisture. In addition, a large-capacity electric fuel pump supplies an appropriate amount of fuel to the engine for improved performance.

Save fuel

Hydraulic loss is decreased by HIOS III B technology. It reduces the hydraulic oil returned to the tank due to the cooperative control of the pump and valve. This helps to lower fuel consumption by 5% in ECO mode with the same productivity.

Engine protection

The combustion chamber is made from stronger materials, and the revised shape of the piston is designed to achieve cleaner emissions. These features will further enhance the reliability of the engine.



ZX890LC-6

Reinforced Undercarriage

New shape of the lower roller

The lower roller has been redesigned to further help prevent mud ingress.

- Long-term durability
- Three track guards come standard for a more durable undercarriage.

Integrated Idler and Adjuster

The front idler and adjuster cylinder have been integrated in the new ZAXIS-6, improving their durability.

Due to this integration, the bracket that had supported the adjuster cylinder is no longer required, resulting in less mud buildup.

Reinforced idler bracket with slanted side frame

The side frame of the idler bracket is slanted on both sides, which enlarges the cross-sectional area of the external surface of the idler bracket.

The design of the idler bracket has been improved to make it easier to remove mud.



Reinforced undercarriage and increased crossbeam size and strength increase durability.

RELIABILITY IS THE BACKBONE OF YOUR BUSINESS

Easy maintenance

The engine cover can be conveniently opened fully from the platform. This provides easy access to the engine compartment and other components for routine maintenance.

- Dust screen prevents plugging, providing increased reliability.



Quickly and easily select between multiple application modes.

Greater flexibility

Thumb mode is included on the ZX490LC-6. This and 10 other modes can be registered on the monitor for easy fitting of attachments to increase versatility.

Long-lasting visibility

Eight standard LED lights enhance visibility for the operator, particularly at night. LED lights use less power, output more light, and last longer than halogen lights.

Reversing Fan

A standard reversing fan reduces debris buildup and increases uptime.





HITACHI

ZA/IS
690LC

Machine representative of global product.
Options may not be available in all markets.

ZX690LC-6

GET MORE FROM YOUR EXCAVATOR

Lower emissions

The after-treatment device consists of a diesel oxidation catalyst (DOC), urea mixing pipe, SCR system, and silencer. This advanced technology helps to reduce emissions and noise levels.

Engine aftertreatment device

Consisting of a DOC, a urea water mixing pipe, a SCR catalyst, and a silencer.

Urea SCR system without DPF reduces NOx

Tier 4 Final is currently achieved by using a combination of urea SCR (Selective Catalytic Reduction) and DOC (Diesel Oxidation Catalyst). The DOC is basically maintenance-free. The amount of urea water is roughly 2% to 3% of the total fuel amount. Easy maintenance without a DPF.



Easy-access DEF tank

Reliable Isuzu engine

Isuzu engines provide the reliability of 5+ years on-site experience in the North American market.



Checking DEF fluid level through Multi-function monitor.

ConSite OIL

ConSite OIL monitors the oil condition to help ease your mind so that you can focus on the work at hand.

- The oil-monitoring sensor attached to the engine and hydraulic equipment monitors the oil status of each operating machine.

Remote monitoring

Global e-Service allows for remote monitoring of your fleet, providing useful excavator data to enhance productivity and minimize downtime. Improve performance and maximize the efficiency of your excavator using the Global e-Service online management tool available 24/7 online.





HITACHI

Machine representative of global product.
Options may not be available in all markets.

ZX690LC-6

ZX690LC-6 SPECIFICATIONS

ENGINE

Model	Isuzu 6WG1
Type	4-cycle water-cooled, common rail direct injection
Aspiration	Variable geometry turbocharged, intercooled, cooled EGR
Aftertreatment	DOC and SCR system
No. of cylinders	6
Rated power	
ISO 14396: 2002 Gross	463 hp (345 kW) at 1,800 rpm
ISO 9249: 2007 Net.....	463 hp (345 kW) at 1,800 rpm
SAE J1349, net: 2011	1,460 lbf-ft (1,500 Nm) at 1,500 rpm
Maximum torque	957 cu in (15.68 L)
Piston displacement	5.8" x 6.1" (147 mm x 154 mm)
Bore and stroke	2 x 12 V / 170 Ah
Batteries	2 x 12 V / 170 Ah

HYDRAULIC SYSTEM

Hydraulic Pumps

Main pumps	2 variable displacement axial piston pumps
Maximum oil flow	2 x 129 gal/m (2 x 489 L/min)
Pilot pump	1 gear pump
Maximum oil flow	13.2 gal/m (50 L/min)

Hydraulic Motors

Travel	2 variable displacement axial piston motors
Swing	2 axial piston motor

Relief Valve Settings

Implement circuit	4,627 psi (31.9MPa)
Swing circuit	4,264 psi (29.4MPa)
Travel circuit	4,975 psi (34.3MPa)
Pilot circuit	566 psi (3.9MPa)
Power boost	4,975 psi (34.3MPa)

Hydraulic Cylinders

Unit: in (mm)

	Quantity	Bore	Rod diameter
Boom	2	7.5" (190)	5.1" (130)
Arm	1	7.9" (200)	5.5" (140)
Bucket	1	7.1" (180)	5.1" (130)

UPPERSTRUCTURE

Revolving Frame

D-section frame for resistance to deformation.

Swing Device

Axial piston motor with planetary reduction gear is bathed in oil. Swing parking brake is spring-set/hydraulic-released disc type.

Swing speed	9.0 rpm
Swing torque	143,087 lbf-ft (194 kNm)

UNDERCARRIAGE

Tracks

Track shoes with triple grousers made of induction-hardened rolled alloy. Heat-treated connecting pins with dirt seals. Hydraulic (grease) track adjusters with shock-absorbing recoil springs.

Numbers of Rollers and Shoes on Each Side

Upper rollers	3
Lower rollers	8
Track shoes	47
Track guards	2

Travel Device

Each track driven by axial piston motor through reduction gear for counter rotation of the tracks. Parking brake is spring-set/hydraulic-released disc type. Automatic transmission system: High-Low.

Travel speeds	High: 0 to 3.2 mph (0 to 5.2 km/h)
	Low: 0 to 2.2 mph (0 to 3.6 km/h)
Maximum traction force	103,412 lbf (460 kN)
Gradeability	70% (35 degree) continuous

ENVIRONMENT

Engine Emissions	EPA Final Tier 4/EU Stage IV
------------------------	------------------------------

SOUND LEVEL

Sound level in cab according to ISO 6396: 2008	LpA 74 dB(A)
External sound level according to ISO 6395: 2008 and EU Directive 2000/14/EC	LwA 108 dB(A)

SERVICE REFILL CAPACITIES

Unit: gal (L)

Fuel tank	238 (900)
Engine coolant	20.1 (76)
Engine oil	15.1 (57)
Swing device.....	2.8 (10.5)
Travel device (each side).....	4.2 (16)
Hydraulic system.....	198 (750)
Hydraulic oil tank.....	100 (380)
DEF/AdBlue® tank.....	25.1 (95)

WEIGHTS AND GROUND PRESSURE

Operating Weight and Ground Pressure

Bucket Capacity	Boom type	Arm type	Shoe grouser type	Shoe width in (mm)	Operating weight lb (kg)	Ground pressure psi (kPa)
3.27 yd ³ (2.5 m ³) (ISO heaped)	25' 7" H (7.8 m H)	13' 9" Semi-long (4.2 m Semi-long)	Double	36" (900)	151,237 (68,600)	10.7 (74)

BUCKET AND ARM DIGGING FORCE

Unit: lbf (kN)

Arm length	13' 9" (4.2 m)
Arm crowd force* ISO 6015: 2006	51,931 (231)
Bucket digging force* ISO 6015: 2006	72,838 (324)

* At power boost

ZX690LC-6 SPECIFICATIONS

DIMENSIONS

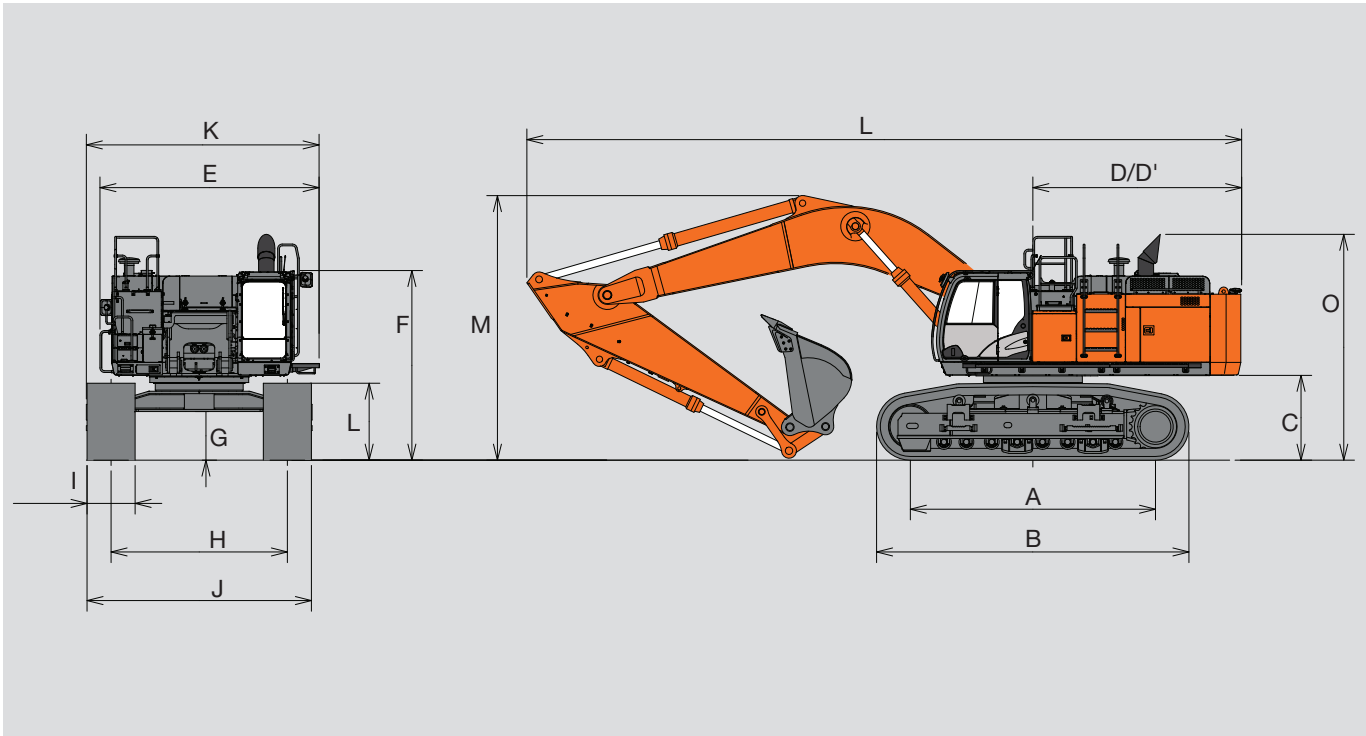

Unit: ft-in (mm)

	ZX490LC-6
A Distance between tumblers	15' 1" (4,590)
B Undercarriage length	19' 2" (5,840)
*C Counterweight clearance	4' 6" (1,530)
D Rear-end swing radius	13' 2" (4,020)
D' Rear-end length	12' 10" (3,910)
E Overall width of upperstructure	13' 5" (4,090)
F Overall height of cab	11' 8" (3,560)
*G Min. ground clearance	2' 10" (860)
H Track gauge; Extended/Retracted	10' 10" (3,300)/9' 3" (2,830)
I Track shoe width	36" (900)
J Undercarriage width; Extended/Retracted	13' 9" (4,200)/12' 3" (3,730)
K Overall width	14' 4" (4,360)
*L Overall length	43' 11" (13,400)
M Overall height of boom	16' 4" (4,980)
N Track height	4' 9" (1,440)
O Overall height of base machine	13' 10" (4,230)

* Excluding track shoe lug

WORKING RANGES

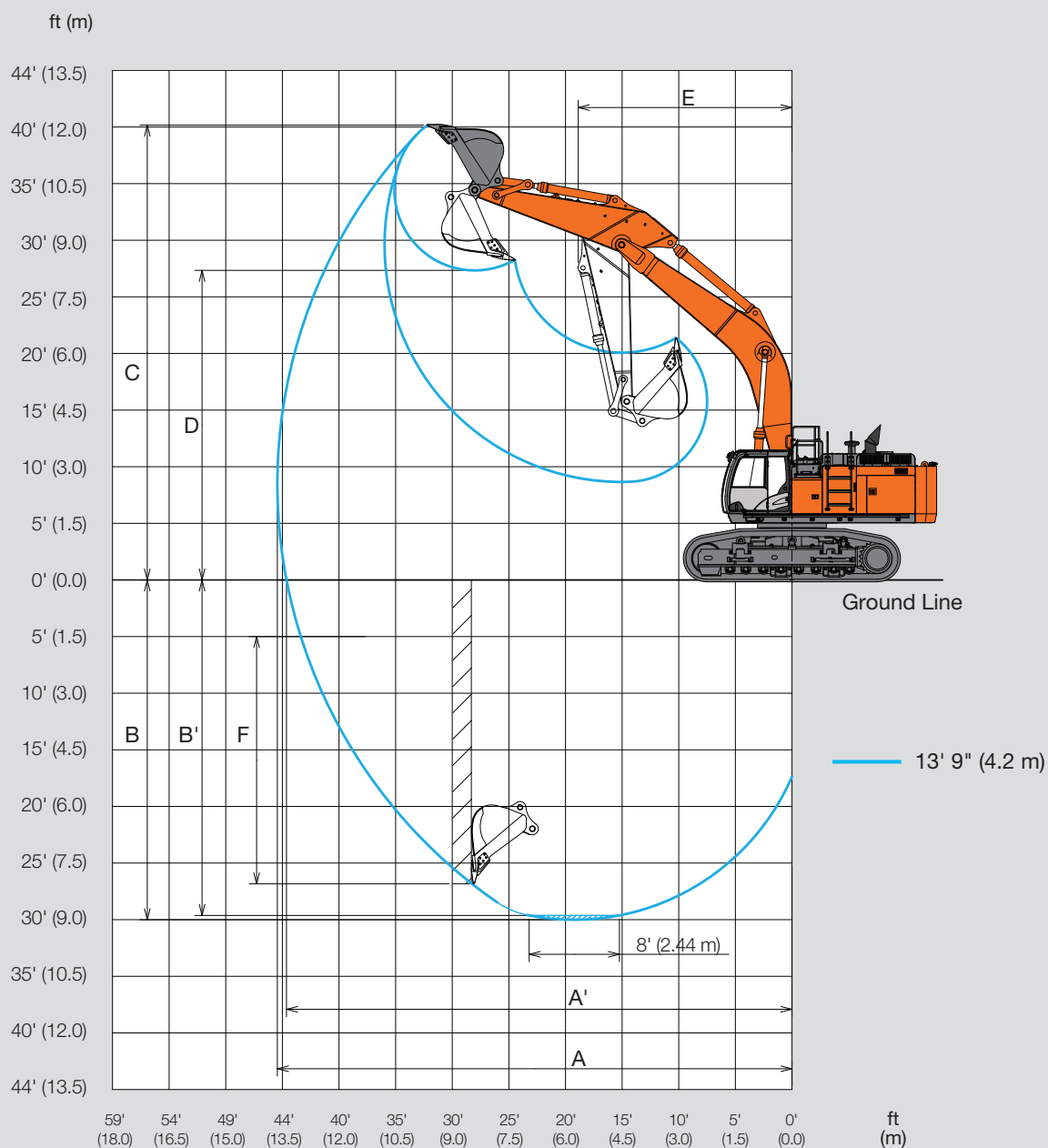

Unit: ft-in (mm)

	ZX690LC-6
Arm length	13' 9" (4.2 m)
A Max. digging reach	45' 5" (13,850)
A' Max. digging reach (on ground)	44' 8" (13,610)
B Max. digging depth	30' (9,150)
B' Max. digging depth for 8' (2.44 m) level	29' 8" (9,030)
C Max. cutting height	40' 2" (12,240)
D Max. dumping height	27' 4" (8,330)
E Min. swing radius	18' 11" (5,760)
F Max. vertical wall digging depth	26' 10" (8,180)

Excluding track shoe lug

ZX690LC-6 MACHINE CAPACITIES

Boldface type indicates hydraulically limited capacity; lightface type indicates stability limited capacities, in lb (kg). All machine capacities are based on ISO 10567 (with power boost). Ratings at bucket lift hook; Machine equipped with standard counterweight and standard gauge; and situated on firm, uniform supporting surface. Total load includes weight of cables, hook, etc. Figures do not exceed 87 percent of hydraulic capacities or 75 percent of weight needed to tip machine.

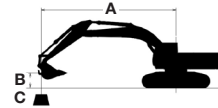

A: Load radius
B: Load point height
C: Machine capacity

ZX690LC-6

Rating over-front Rating over-side or 360 degrees Unit: lb (kg)

Conditions	Load point height ft (m)	Load radius											
		10' (3.0 m)		15' (4.5 m)		20' (6.0 m)		25' (7.5 m)		30' (9.0 m)		35' (10.5 m)	
Boom 25'7" H (7.8 m)	25' (7.5 m)									23,790 (10,790)	23,790 (10,790)		
	20' (6.0 m)									25,460 (11,540)	25,460 (11,540)	20,250 (9,185)	19,630 (8,904)
Arm 13' 9" (4.2 m)	15' (4.5 m)			54,750 (24,830)	54,750 (24,830)	39,600 (17,960)	39,600 (17,960)	32,080 (14,550)	32,080 (14,550)	27,710 (12,560)	25,530 (11,580)	25,020 (11,340)	19,200 (8,700)
	10' (3.0 m)					46,870 (21,250)	46,870 (21,250)	36,260 (16,440)	33,010 (14,970)	30,190 (13,690)	24,420 (11,070)	26,400 (11,970)	18,580 (8,420)
Bucket 4,740 lb (2,150 kg)	5' (1.5 m)					52,390 (23,760)	44,360 (20,120)	39,820 (18,060)	31,380 (14,230)	32,420 (14,700)	23,410 (10,610)	26,480 (12,010)	17,980 (8,150)
	0 (Ground)			32,800 (14,870)	32,800 (14,870)	55,260 (25,060)	42,760 (19,390)	42,130 (19,100)	30,210 (13,700)	33,370 (15,130)	22,630 (10,260)	25,980 (11,780)	17,510 (7,940)
Counterweight 21,605 lb (9,800 kg)	5' (1.5 m)	24,430 (11,080)	24,430 (11,080)	45,600 (20,680)	45,600 (20,680)	55,570 (25,200)	42,030 (19,060)	42,840 (19,430)	29,550 (13,400)	32,870 (14,900)	22,160 (10,050)	25,740 (11,670)	17,290 (7,840)
	10' (3.0 m)	40,170 (18,220)	40,170 (18,220)	63,880 (28,970)	63,880 (28,970)	53,470 (24,250)	41,960 (19,030)	41,640 (18,880)	29,380 (13,320)	32,780 (14,860)	22,070 (10,010)		
Double grouser shoes 36" (900 mm)	15' (4.5 m)	59,140 (26,820)	59,140 (26,820)	63,390 (28,750)	63,390 (28,750)	48,600 (22,040)	42,460 (19,250)	37,850 (17,160)	29,720 (13,480)	28,680 (13,000)	22,520 (10,210)		
	20' (6.0 m)			51,240 (23,240)	51,240 (23,240)	39,460 (17,890)	39,460 (17,890)	28,970 (13,140)	28,970 (13,140)				

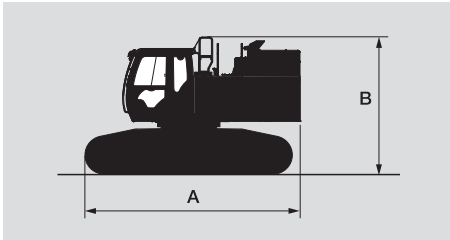

BASIC MACHINE (WITHOUT COUNTERWEIGHT)

Shoe width in (mm)	A ft-in (mm)	B ft-in (mm)	Overall width* ft-in (mm)	Weight lb (kg)
36" (900 mm)	21' 11" (6,700)	13' 11" (4,230)	12'3" (3,730)	97,003 (44,000)

*Undercarriage retracted, without additional step

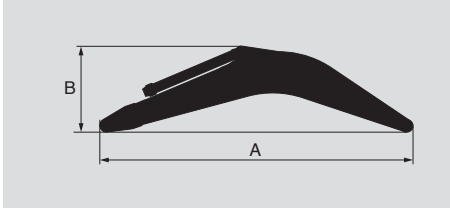

BOOM

Boom	A ft-in (mm)	B ft-in (mm)	C ft-in (mm)	Weight lb (kg)
25'7" H (7.8m H)	26' 8" (8,130)	7' 8" (2,330)	4' 7" (1,390)	14,462 (6,560)

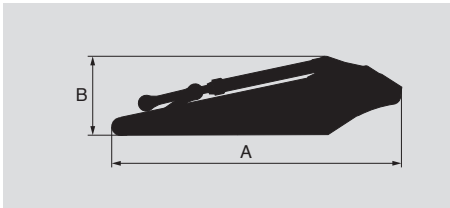

ARM

Arm	A ft-in (mm)	B ft-in (mm)	C ft-in (mm)	Weight lb (kg)
13' 9" Semi-long (4.2 m Semi-long)	18' 9" (5,710)	4' 7" (1,390)	2' 7" (790)	8,664 (3,930)

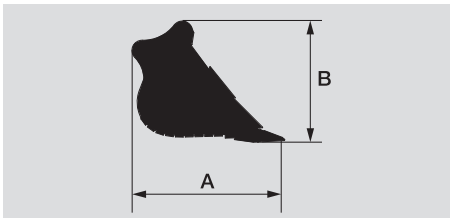

BUCKET

Bucket	Capacity yd ³ (m ³)	A ft-in (mm)	B ft-in (mm)	Overall width ft-in (mm)	Weight lb (kg)
	ISO heaped				
General purpose	3.27 (2.5)	7' 3" (2,220)	5' 11" (1,810)	5' 4" (1,620)	4,740 (2,150)

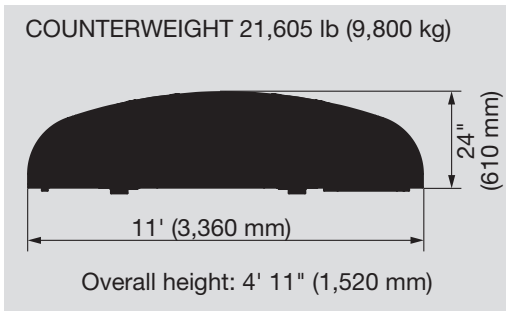

LEFT FRONT SIDEWALK 121 lb (55 kg)

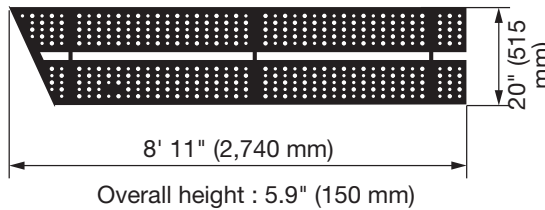

LEFT REAR SIDEWALK 66 lb (30 kg)

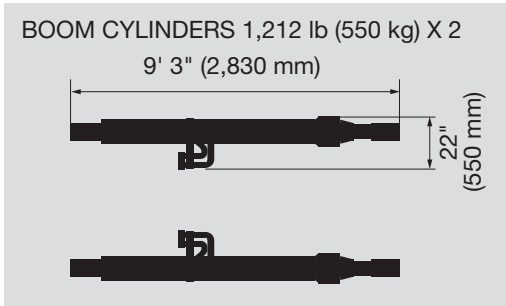
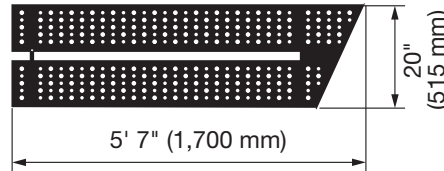

HOSE OF BOOM CYLINDER 15 lb (7 kg) X 2 / 22 lb (10 kg) X 2

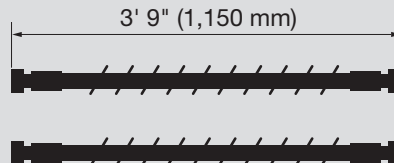

ZX690LC-6 EQUIPMENT

●: Standard equipment ○: Optional equipment

ENGINE	ZX690LC-6
Aftertreatment device	●
Air cleaner double filters	●
Alternator 50 A	●
Auto idle system	●
Auto shut-down control	●
Cartridge-type engine oil filter	●
Cartridge-type fuel main filter	●
ConSite OIL (Sensor)*	●
DEF/AdBlue® tank inlet strainer and extension filler	●
DEF/AdBlue® tank	●
Dry-type air filter with evacuator valve (with air filter restriction indicator)	●
Dust-proof net	●
ECO/PWR/HP mode control	●
Engine oil drain coupler	●
Electrical fuel feed pump	●
Expansion tank	●
Fan guard	●
Fuel cooler	●
Fuel pre-filter	●
Isolation-mounted engine	●
Radiator, oil cooler and intercooler	●
Water separator	●

HYDRAULIC SYSTEM	ZX690LC-6
Auto power lift	●
Boom mode selector system	●
ConSite OIL (Sensor)*	●
Control valve with main relief valve	●
Drain filter	●
Engine speed sensing system	●
Extra port for control valve	●
Full flow filter	●
Pilot filter	●
Power boost	●
Quick warm-up system for pilot circuit	●
Shockless valve in pilot circuit	●
Suction filter	●
Work mode selector	●

* Engine oil and hydraulic oil monitoring sensor.

CAB	ZX690LC-6
All-weather sound suppressed steel cab	●
AM-FM radio	●
Ashtray	●
Auto control air conditioner	●
AUX terminal and storage	●
Cigarette lighter 24 V	●
Drink holder with hot & cool function	●
Electric double horn	●
Engine shut-off switch	●
Evacuation hammer	●
Floor mat	●
Footrest	●
Front window washer	●
Glove compartment	●
Hot and cool box	●
Intermittent windshield wipers	●
Key cylinder light	●
Laminated round glass front window	●
LED room light with door courtesy	●
Lever auto locking function	●
Motion alarm with cancel switch (conforms to SAE J994: 2014)	●
OPG top guard Level I (ISO 10262: 1998) compliant cab	●
Pilot control shut-off lever	●
Power outlet 12 V	●
Rain guard	●
Rear tray	●
Retractable seat belt 3 in.	●
ROPS (ISO 12117-2: 2008) compliant cab	●
Rubber radio antenna	●
Seat: air suspension seat with heater	●
Seat adjustment part: backrest, armrest, height and angle, slide forward/back	●
Short wrist control levers	●
Sun visor (multi-use front or side and rear window)	●
Transparent roof with slide curtain	●
USB power supply	●
2 speakers	●
6 fluid-filled elastic mounts	●

MONITOR SYSTEM	ZX690LC-6
Alarms: overheat, engine warning, engine oil pressure, alternator, minimum fuel level, hydraulic filter restriction, air filter restriction, work mode, SCR system trouble, etc.	●
Alarm buzzers: overheat, engine oil pressure, SCR system trouble	●
Display of meters: water temperature, hour, fuel rate, clock, DEF/AdBlue® rate	●
Other displays: work mode, auto-idle, glow, rearview monitor, operating conditions, etc.	●
32-language selection	●

LIGHTS	ZX690LC-6
Additional boom LED light with cover	●
Additional cab roof front LED lights	●
LED lights for camera (side and rearview camera)	●
2 working LED lights	●

UPPERSTRUCTURE	ZX690LC-6
AERIAL ANGLE® (270-degree view camera system)	●
Batteries 2 x 170 Ah	●
Battery disconnect switch	●
Body top handrail	●
Counterweight 21,605 lb (9,800 kg)	●
Counterweight removal system	●
Electric fuel refilling pump with auto stop and filter	●
Fuel level float	●
Hydraulic oil level gauge	●
Ladder	●
Lockable fuel refilling cap	●
Lockable machine covers	●
Lockable tool box	●
Platform handrail	●
Rear view mirror (right and left)	●
Sidewalk (cab side)	●
Skid-resistant plates and handrails	●
Swing parking brake	●
Undercover	●
Utility space	●

●: Standard equipment ○: Optional equipment

UNDERCARRIAGE	ZX690LC-6
Bolt-on sprocket	●
Reinforced track links with pin seals	●
Shoe: 36" (900 mm) triple grouser	●
Travel direction mark on track frame	●
Travel motor covers	●
Travel parking brake	●
Upper and lower rollers	●
2 track guard (each side) and hydraulic track adjuster	●
4 tie-down brackets	●

ATTACHMENTS	ZX690LC-6
ConSite	○
Global e-Service	●
Onboard information controller	●
Standard tool kit	●

FRONT ATTACHMENTS	ZX690LC-6
Arm 13' 9" Semi-long (4.2m Semi-long)	●
Boom 25'7" H (7.8m H)	●
Casted bucket link A	●
Centralized lubrication system	●
Dirt seal on all bucket pins	●
Flanged pin	●

Standard and optional equipment may vary by country, so please consult your Hitachi dealer for details.

Net engine power is with standard equipment including air cleaner, exhaust system, alternator and cooling fan, at test conditions specified per ISO 9249 :2007. No derating is required up to 6,600 ft. (2,000m) altitude.

Specifications and design subject to change without notice. Wherever applicable, specifications are in accordance with SAE standards. Except where otherwise noted, these specifications are based on units with 13' 9" (4.2m) Arms; 58" (1,480mm), 4,740 lb (2,150kg) buckets; 21,605 lb (9,800kg) counterweights; full fuel tanks; 165 lb (75kg) operators; and a ZX690LC-6 unit with 36" (900mm) double grouser shoes.

ZX890LC-6 SPECIFICATIONS

ENGINE

Model	Isuzu 6WG1
Type	4-cycle water-cooled, common rail direct injection
Aspiration	Variable geometry turbocharged, intercooled, cooled EGR
Aftertreatment	DOC and SCR system
No. of cylinders	6
Rated power	
ISO 14396: 2002 Gross	512 hp (382 kW) at 1,800 rpm
ISO 9249: 2007 Net.....	512 hp (382 kW) at 1,800 rpm
Maximum torque	1,622 lbf-ft (2,220 Nm) at 1,450 rpm
Piston displacement	957 cu in (15.68 L)
Bore and stroke	5.8" x 6.1" (147 mm x 154 mm)
Batteries	2 x 12 V/170 Ah

HYDRAULIC SYSTEM

Hydraulic Pumps

Main pumps	2 variable displacement axial piston pumps
Maximum oil flow	2 x 147 gal/m (2 x 556 L/min)
Pilot pump	1 gear pump
Maximum oil flow	13.2 gal/m (50 L/min)

Hydraulic Motors

Travel	2 variable displacement axial piston motors
Swing	2 axial piston motor

Relief Valve Settings

Implement circuit	4,627 psi (31.9 MPa)
Swing circuit	4,119 psi (28.4 MPa)
Travel circuit	4,975 psi (34.3 MPa)
Pilot circuit	566 psi (3.9 MPa)
Power boost	4,975 psi (34.3 MPa)

Hydraulic Cylinders

Unit: in (mm)

	Quantity	Bore	Rod diameter
Boom	2	8.5" (215)	5.9" (150)
Arm	1	8.9" (225)	6.3" (160)
Bucket	1	7.9" (200)	5.5" (140)

UPPERSTRUCTURE

Revolving Frame

D-section frame for resistance to deformation.

Swing Device

Axial piston motor with planetary reduction gear is bathed in oil. Swing parking brake is spring-set/hydraulic-released disc type.

Swing speed	7.8 rpm
Swing torque	196,929 lbf-ft (267 kNm)

UNDERCARRIAGE

Tracks

Track shoes with triple grousers made of induction-hardened rolled alloy. Heat-treated connecting pins with dirt seals. Hydraulic (grease) track adjusters with shock-absorbing recoil springs.

Numbers of Rollers and Shoes on Each Side

Upper rollers	3
Lower rollers	9
Track shoes	51
Track guards	2

Travel Device

Each track driven by axial piston motor through reduction gear for counter rotation of the tracks. Parking brake is spring-set/hydraulic-released disc type. Automatic transmission system: High-Low.

Travel speeds	High: 0 to 2.9 mph (0 to 4.7 km/h)
	Low: 0 to 2.0 mph (0 to 3.2 km/h)
Maximum traction force	125,893 lbf (560 kN)
Gradeability	70% (35 degree) continuous

ENVIRONMENT

Engine Emissions	EPA Final Tier 4/EU Stage IV
------------------------	------------------------------

SOUND LEVEL

Sound level in cab according to ISO 6396: 2008	LpA 75 dB(A)
External sound level according to ISO 6395: 2008 and EU Directive 2000/14/EC	LwA 108 dB(A)

SERVICE REFILL CAPACITIES

Unit: gal (L)

Fuel tank	293 (1,110)
Engine coolant	32.8 (124)
Engine oil	15.1 (57)
Swing device.....	4.1 (15.7)
Travel device (each side).....	5 (19)
Hydraulic system.....	275 (1,042)
Hydraulic oil tank.....	132 (500)
DEF/AdBlue® tank.....	25.1 (95)

WEIGHTS AND GROUND PRESSURE

Operating Weight and Ground Pressure

Bucket Capacity	Boom type	Arm type	Shoe grouser type	Shoe width in (mm)	Operating weight lb (kg)	Ground pressure psi (kPa)
3.79 yd ³ (2.9 m ³) (ISO heaped)	27' 7" H (8.4 m H)	14' 5" Semi-long (4.4 m Semi-long)	Double	36" (900)	186,511 (84,600)	12 (83)

BUCKET AND ARM DIGGING FORCE

Unit: lbf (kN)

Arm length	14' 5" (4.4 m)
Arm crowd force* ISO 6015: 2006	62,946 (280)
Bucket digging force* ISO 6015: 2006	89,699 (399)

* At power boost

ZX890LC-6 SPECIFICATIONS

DIMENSIONS

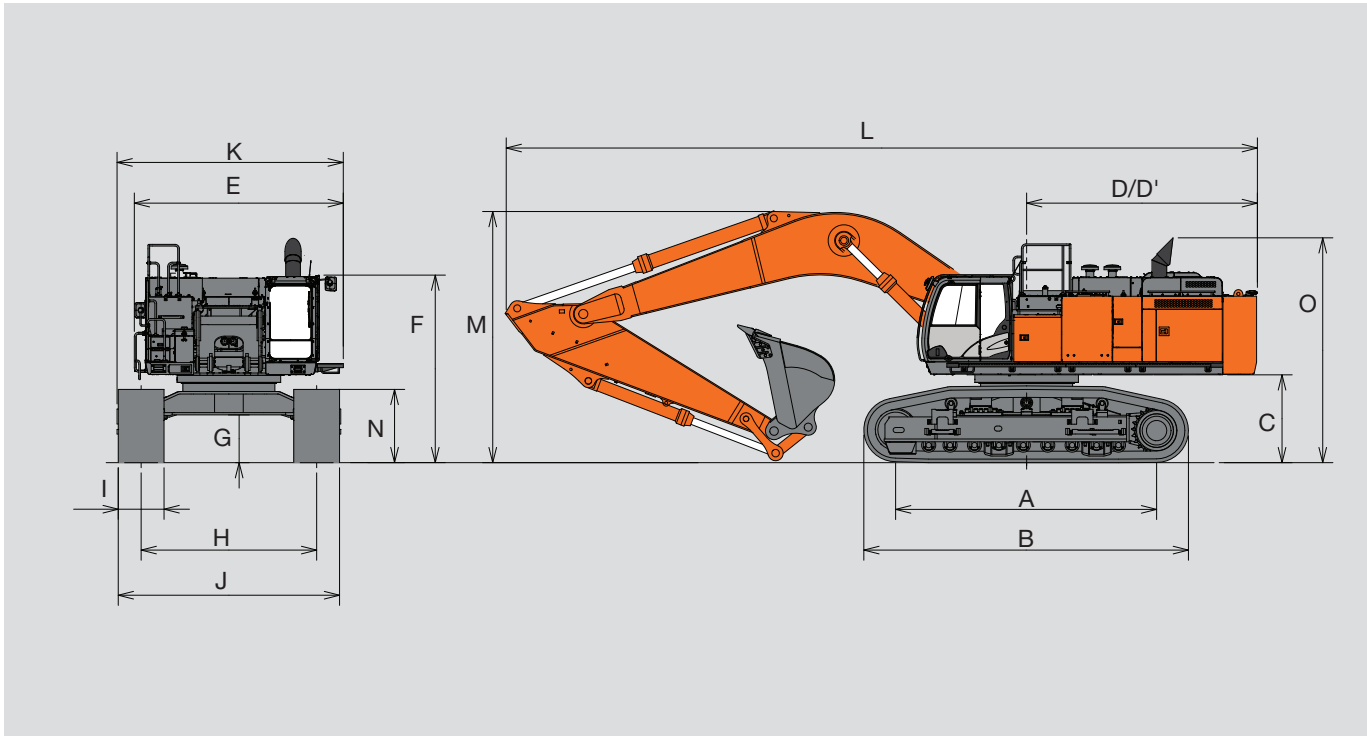

Unit: ft-in (mm)

	ZX890LC-6	
A	Distance between tumblers	16' 9" (5,110)
B	Undercarriage length	20' 10" (6,360)
*C	Counterweight clearance	5' 6" (1,680)
D	Rear-end swing radius	15' 1" (4,600)
D'	Rear-end length	14' 11" (4,540)
E	Overall width of upperstructure	13' 6" (4,120)
F	Overall height of cab	12' 1" (3,690)
*G	Min. ground clearance	2' 11" (890)
H	Track gauge; Exrtended/Retracted	11' 4" (3,450) / 9' 3" (2,830)
I	Track shoe width	36" (900)
J	Undercarriage width; Exrtended/Retracted	14' 3" (4,350) / 12' 3" (3,730)
K	Overall width	14' 7" (4,450)
*L	Overall length	48' 7" (14,800)
M	Overall height of boom	16' 10" (5,130)
N	Track height	4' 11" (1,500)
O	Overall height of base machine	14' 6" (4,410)

* Excluding track shoe lug

WORKING RANGES

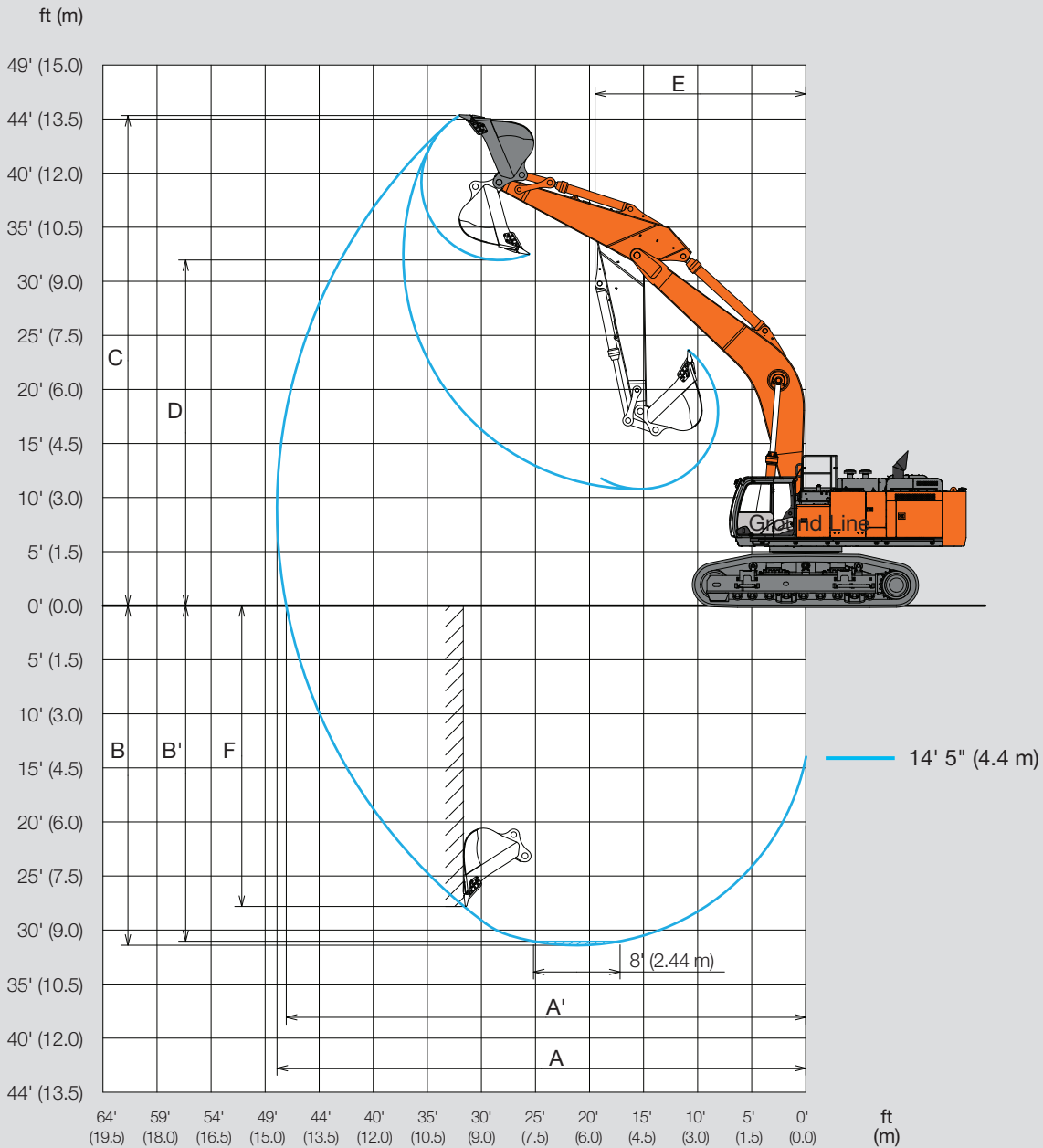

Unit: ft-in (mm)

	ZX890LC-6
Arm length	14' 5" (4.4 m)
A Max. digging reach	48' 11" (14,910)
A' Max. digging reach (on ground)	48' (14,640)
B Max. digging depth	31' 5" (9,570)
B' Max. digging depth for 8' (2.44 m) level	31' (9,460)
C Max. cutting height	45' 4" (13,820)
D Max. dumping height	31' 11" (9,740)
E Min. swing radius	19' 6" (5,950)
F Max. vertical wall digging depth	27' 10" (8,480)

Excluding track shoe lug

ZX890LC-6 MACHINE CAPACITIES

Boldface type indicates hydraulically limited capacity; lightface type indicates stability limited capacities, in lb (kg). All machine capacities are based on ISO 10567 (with power boost). Ratings at bucket lift hook; Machine equipped with standard counterweight and standard gauge; and situated on firm, uniform supporting surface. Total load includes weight of cables, hook, etc. Figures do not exceed 87 percent of hydraulic capacities or 75 percent of weight needed to tip machine.

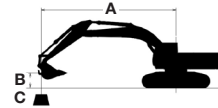

A: Load radius
B: Load point height
C: Machine capacity

ZX890LC-6

Rating over-front Rating over-side or 360 degrees Unit: lb (kg)

Conditions	Load point height ft (m)	Load radius													
		10' (3.0 m)		15' (4.5 m)		20' (6.0 m)		25' (7.5 m)		30' (9.0 m)		35' (10.5 m)		40' (12.0 m)	
Boom 27' 7" H (8.4 m) Arm 14' 5" (4.4 m) Bucket 5,952 lb (2,700 kg) Counterweight 27,337 lb (12,400 kg) Double grouser shoes 36" (900 mm)	30' (9.0 m)									27,690 (12,550)	27,690 (12,550)	19,450 (8,820)	19,450 (8,820)		
	25' (7.5 m)									29,450 (13,350)	29,450 (13,350)	24,640 (11,170)	24,640 (11,170)		
	20' (6.0 m)							36,620 (16,610)	36,620 (16,610)	32,180 (14,590)	32,180 (14,590)	29,370 (13,320)	27,440 (12,440)	16,450 (7,460)	16,450 (7,460)
	15' (4.5 m)					54,120 (24,540)	54,120 (24,540)	42,250 (19,160)	42,250 (19,160)	35,520 (16,110)	34,820 (15,790)	31,320 (14,200)	26,550 (12,040)	23,410 (10,610)	20,450 (9,270)
	10' (3.0 m)					63,590 (28,840)	62,000 (28,120)	47,810 (21,680)	44,520 (20,190)	38,940 (17,660)	33,230 (15,070)	33,400 (15,140)	25,580 (11,600)	27,730 (12,570)	19,980 (9,060)
	5' (1.5 m)					69,870 (31,690)	59,690 (27,070)	52,240 (23,690)	42,400 (19,230)	41,870 (18,990)	31,860 (14,450)	35,220 (15,970)	24,700 (11,200)	29,650 (13,440)	19,500 (8,840)
	0 (Ground)					68,030 (30,850)	58,010 (26,310)	54,870 (24,880)	40,980 (18,580)	43,820 (19,870)	30,830 (13,980)	36,390 (16,500)	24,020 (10,890)	26,770 (12,140)	19,140 (8,680)
	-5' (1.5 m)			37,550 (17,030)	37,550 (17,030)	72,030 (32,670)	57,370 (26,020)	55,510 (25,170)	40,230 (18,240)	44,410 (20,140)	30,230 (13,710)	36,500 (16,550)	23,640 (10,720)		
	-10' (3.0 m)	37,410 (16,960)	37,410 (16,960)	57,060 (25,880)	57,060 (25,880)	69,030 (31,310)	57,450 (26,050)	54,000 (24,490)	40,060 (18,170)	43,250 (19,610)	30,070 (13,630)	34,820 (15,790)	23,640 (10,720)		
	-15' (4.5 m)	57,580 (26,110)	57,580 (26,110)	81,680 (37,040)	81,680 (37,040)	63,220 (28,670)	58,120 (26,360)	49,890 (22,620)	40,450 (18,340)	39,500 (17,910)	30,430 (13,800)				
-20' (6.0 m)			68,100 (30,880)	68,100 (30,880)	53,450 (24,240)	53,450 (24,240)	41,730 (18,920)	41,520 (18,830)							

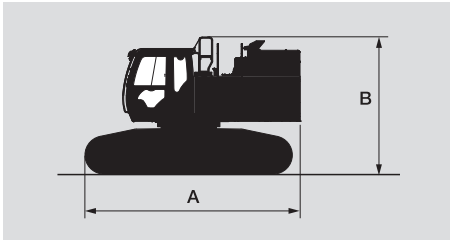

BASIC MACHINE (WITHOUT COUNTERWEIGHT)

Shoe width in (mm)	A ft-in (mm)	B ft-in (mm)	Overall width* ft-in (mm)	Weight lb (kg)
36" (900 mm)	24' 8" (7,530)	14' 6" (4,410)	12'3" (3,730)	121,254 (55,000)

*Undercarriage retracted, without additional step

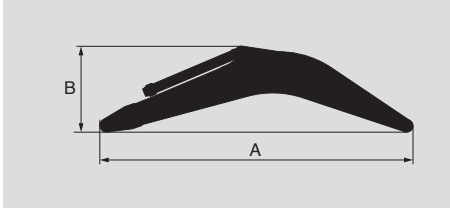

BOOM

Boom	A ft-in (mm)	B ft-in (mm)	C ft-in (mm)	Weight lb (kg)
27' 7" H (8.4 m H)	28' 9" (8,760)	8' 3" (2,510)	4' 9" (1,440)	18,100 (8,210)

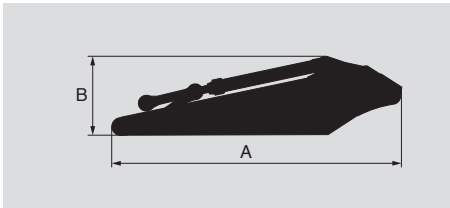

ARM

Arm	A ft-in (mm)	B ft-in (mm)	C ft-in (mm)	Weight lb (kg)
14' 5" Semi-long (4.4 m Semi-long)	19' 3" (5,870)	4' 7" (1,400)	2' 8" (810)	10,229 (4,630)

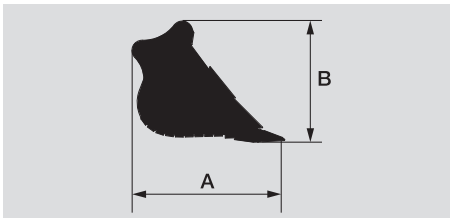

BUCKET

Bucket	Capacity yd ³ (m ³)	A ft-in (mm)	B ft-in (mm)	Overall width ft-in (mm)	Weight lb (kg)
	ISO heaped				
General purpose	3.79 (2.9)	7' 3" (2,210)	6' 3" (1,910)	5' 10" (1,780)	5,952 (2,700)

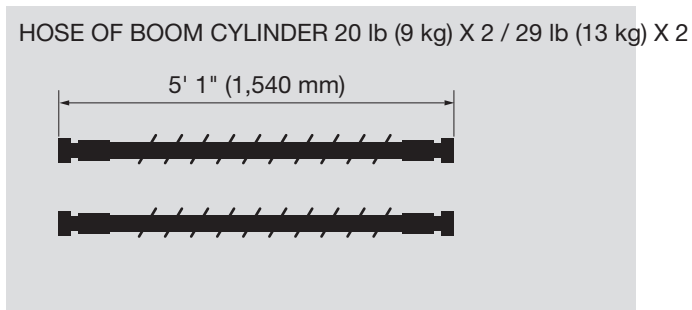
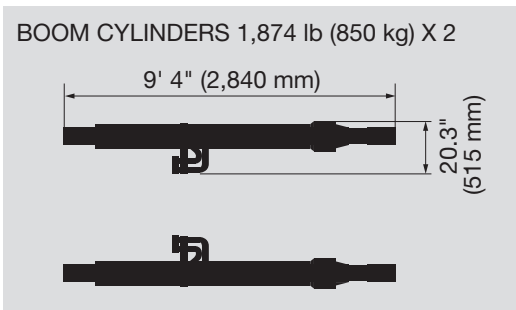
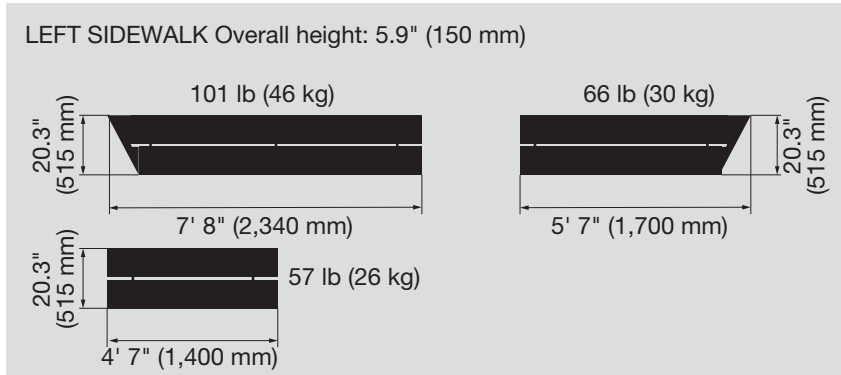
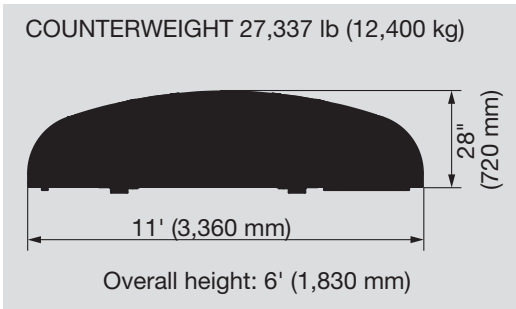

ZX890LC-6 EQUIPMENT

ENGINE	ZX890LC-6
Aftertreatment device	●
Air cleaner double filters	●
Alternator 50 A	●
Auto idle system	●
Auto shut-down control	●
Cartridge-type engine oil filter	●
Cartridge-type fuel main filter	●
ConSite OIL (Sensor)*	●
DEF/AdBlue® tank inlet strainer and extension filler	●
DEF/AdBlue® tank	●
Dry-type air filter with evacuator valve (with air filter restriction indicator)	●
Dust-proof net	●
ECO/PWR/HP mode control	●
Engine oil drain coupler	●
Electrical fuel feed pump	●
Expansion tank	●
Fan guard	●
Fuel cooler	●
Fuel pre-filter	●
Isolation-mounted engine	●
Radiator, oil cooler and intercooler	●
Water separator	●

HYDRAULIC SYSTEM	ZX890LC-6
Auto power lift	●
Boom mode selector system	●
ConSite OIL (Sensor)*	●
Control valve with main relief valve	●
Drain filter	●
Engine speed sensing system	●
Extra port for control valve	●
Full flow filter	●
Pilot filter	●
Power boost	●
Quick warm-up system for pilot circuit	●
Shockless valve in pilot circuit	●
Suction filter	●
Work mode selector	●

* Engine oil and hydraulic oil monitoring sensor.

CAB	ZX890LC-6
All-weather sound suppressed steel cab	●
AM-FM radio	●
Ashtray	●
Auto control air conditioner	●
AUX terminal and storage	●
Cigarette lighter 24 V	●
Drink holder with hot & cool function	●
Electric double horn	●
Engine shut-off switch	●
Evacuation hammer	●
Floor mat	●
Footrest	●
Front window washer	●
Glove compartment	●
Hot and cool box	●
Intermittent windshield wipers	●
Key cylinder light	●
Laminated round glass front window	●
LED room light with door courtesy	●
Lever auto locking function	●
Motion alarm with cancel switch (conforms to SAE J994: 2014)	●
OPG top guard Level I (ISO 10262: 1998) compliant cab	●
Pilot control shut-off lever	●
Power outlet 12 V	●
Rain guard	●
Rear tray	●
Retractable seat belt 3 in.	●
ROPS (ISO 12117-2: 2008) compliant cab	●
Rubber radio antenna	●
Seat: air suspension seat with heater	●
Seat adjustment part: backrest, armrest, height and angle, slide forward/back	●
Short wrist control levers	●
Sun visor (multi-use front or side and rear window)	●
Transparent roof with slide curtain	●
USB power supply	●
2 speakers	●
6 fluid-filled elastic mounts	●

●: Standard equipment ○: Optional equipment

MONITOR SYSTEM	ZX890LC-6
Alarms: overheat, engine warning, engine oil pressure, alternator, minimum fuel level, hydraulic filter restriction, air filter restriction, work mode, SCR system trouble, etc.	●
Alarm buzzers: overheat, engine oil pressure, SCR system trouble	●
Display of meters: water temperature, hour, fuel rate, clock, DEF/AdBlue® rate	●
Other displays: work mode, auto-idle, glow, rearview monitor, operating conditions, etc.	●
32-language selection	●

LIGHTS	ZX890LC-6
Additional boom LED light with cover	●
Additional cab roof front LED lights	●
LED lights for camera (side and rearview camera)	●
2 working LED lights	●

UPPERSTRUCTURE	ZX890LC-6
AERIAL ANGLE® (270-degree view camera system)	●
Batteries 2 x 170 Ah	●
Battery disconnect switch	●
Body top handrail	●
Counterweight 27,337 lb (12,400 kg)	●
Counterweight removal system	●
Electric fuel refilling pump with auto stop and filter	●
Fuel level float	●
Hydraulic oil level gauge	●
Ladder	●
Lockable fuel refilling cap	●
Lockable machine covers	●
Lockable tool box	●
Platform handrail	●
Rear view mirror (right and left)	●
Sidewalk (cab side)	●
Skid-resistant plates and handrails	●
Swing parking brake	●
Undercover	●
Utility space	●

●: Standard equipment ○: Optional equipment

UNDERCARRIAGE	ZX890LC-6
Bolt-on sprocket	●
Reinforced track links with pin seals	●
Shoe: 36" (900mm) double grouser	●
Travel direction mark on track frame	●
Travel motor covers	●
Travel parking brake	●
Upper and lower rollers	●
2 track guard (each side) and hydraulic track adjuster	●
4 tie down brackets	●

ATTACHMENTS	ZX890LC-6
ConSite	○
Global e-Service	●
Onboard information controller	●
Standard tool kit	●

FRONT ATTACHMENTS	ZX890LC-6
Arm 14' 5" Semi-long (4.4 m Semi-long)	●
Boom 27' 7" H (8.4 m H)	●
Casted bucket link A	●
Centralized lubrication system	●
Dirt seal on all bucket pins	●
Flanged pin	●

Standard and optional equipment may vary by country, so please consult your Hitachi dealer for details.

Net engine power is with standard equipment including air cleaner, exhaust system, alternator and cooling fan, at test conditions specified per ISO 9249: 2007. No derating is required up to 6,600 ft. (2,000m) altitude.

Specifications and design subject to change without notice. Wherever applicable, specifications are in accordance with SAE standards. Except where otherwise noted, these specifications are based on units with 14' 5" (4.4 m) Arms; 60" (1,590 mm), 5,952 lb (2,700 kg) buckets; 27,337 lb (12,400kg) counterweights; full fuel tanks; 165 lb (75 kg) operators; and a ZX890LC-6 unit with 36" (900 mm) double grouser shoes.



HITACHI

Reliable solutions



REPUTATIONS ARE
BUILT ON IT.

With manufacturing facilities in Banshu, Ryugasaki, Tierra, Hitachinaka, and Tsuchiura, Japan, and the U.S. corporate office and campus in Newnan, Georgia, Hitachi Construction Machinery Americas Inc. (HCMA) has the experience and technology to design, engineer, manufacture, and service your Hitachi construction machinery. The HCMA team is securely poised as your go-to source in the North American and Latin American construction machinery markets.

Through our long-term commitment to maintaining a leadership position in technology, service, and support, HCMA supports an extensive network of independent, local dealers focused on providing you with knowledgeable and experienced sales, service, and parts personnel — all backed by dedicated HCMA support teams.

Your HCMA dealer has the resources, expertise, and personnel to work with you to ensure that you receive the most benefit from your Hitachi investment, utilizing carefully designed programs and services in conjunction with extensive digital resources. HCMA provides a totally focused approach to supporting you, your business, and your Hitachi construction machinery.

Machines representative of global product. Options may not be available in all markets. Prior to operating this machine, including satellite communication system, in a country other than a country of its intended use, it may be necessary to make modifications to it so that it complies with the local regulatory standards (including safety standards) and legal requirements of that particular country. Please do not export or operate this machine outside the country of its intended use until such compliance has been confirmed. Please contact your Hitachi dealer in case of questions about compliance.